

NEON LAMP

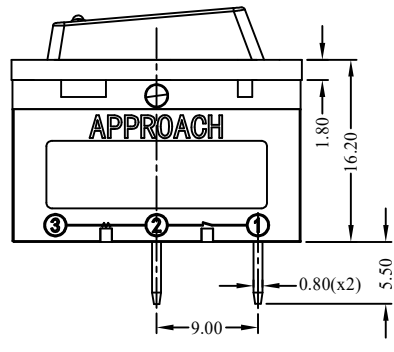

SW

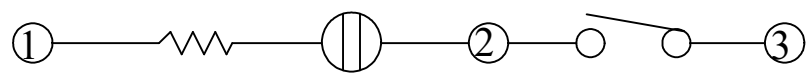

CIRCUIT DIAGRAM

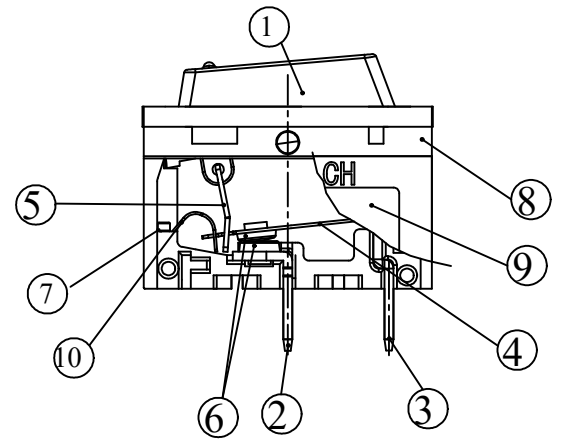

ASSEMBLE DRAWING

1. Model : SS-007
型号：SS-007
2. UL file No. : E152074
UL档案号：E152074
3. Ampere Rating: 3~20A
额定电流：3~20A
4. Rated Voltage: 125V/250VAC 32VDC
额定电压：125V/250VAC 32VDC
5. Short-Circuit Ability: 125VAC 2.0KA; 250VAC 1.0KA;32VDC 1.0KA
短路能力：125VAC 2.0KA; 250VAC 1.0KA;32VDC 1.0KA
6. Dielectric Strength: 1000VAC plus twice the maximum rated voltage for 1 minute
介电强度：1000VAC 加上两倍额定电压1分钟
7. Overload Ability: six Times rated current
过载能力：6倍额定电流
8. Temperature Rise at Terminal Block:Less than 65K
at 100% of rated current applied continuously
接线端子温升：小于65K，额定电流的100%连续施加
9. Parts and materials as per list
零件和材料如列表所示
10. Structure and dimension as per drawing
结构和尺寸如图所示
11. Unless otherwise specified dimensions are in millimeters. tolerance : ±0.3mm
除非另有说明，尺寸以毫米为单位.公差：±0.3mm

NO.	PARTS NAME		QTY PCS/SET	MATERIAL	
1	knob	开关盖	1	PC	聚碳酸酯
2	terminal #2	端子#2	1	copper alloy	铜合金
3	terminal #3	端子#3	1	copper alloy	铜合金
4	bimetal	合金片	1	bi-metal	合金片
5	connection rod	拉片	1	stainless	钢材
6	electrical contact	触点	2	AgSnO ₂	银锡合金
7	screw	螺丝	1	cold roll steel	铁材
8	body	本体壳	1	nylon+G.F.	尼龙
9	cover	边壳	1	nylon+G.F.	尼龙
10	bow spring	弹片	1	stainless	钢材

ZONGPRO (DONGGUAN) ELECTRICAL INC.
中坡(東莞)電器股份有限公司

MATERIAL AS TABLE	UNIT mm	SCALE NONE	TITLE
FINISH AS TABLE		SHEET 1/1	CIRCUIT BREAKER WITH POWER SWITCH
APPROVE.	DESIGN ZLQ	DATE 2023.4.07	ART.NO SS-007/CHNTN
			REV A.1